

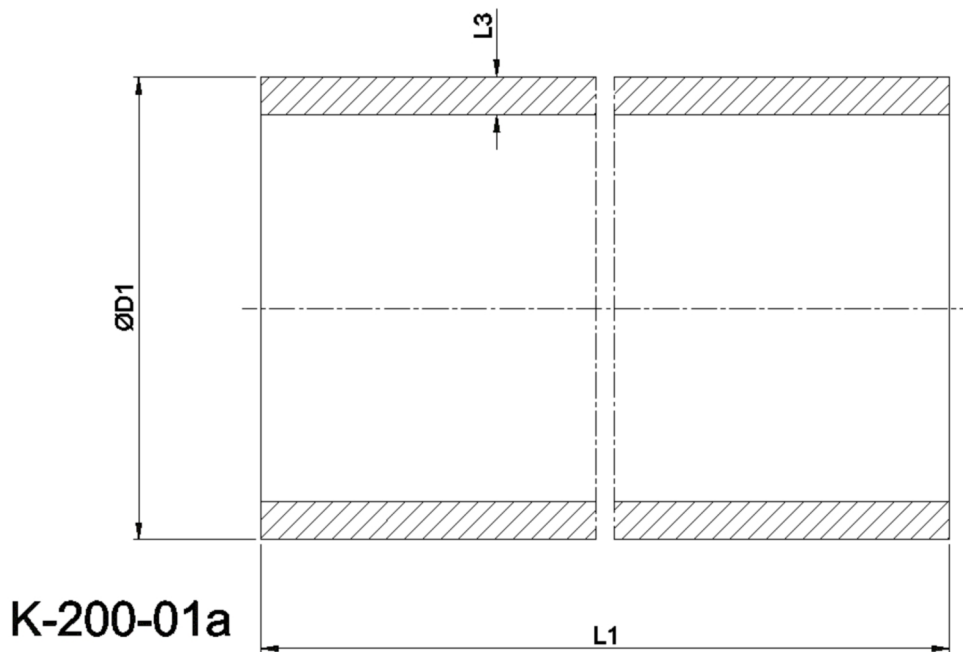

| | | |
|--|--|--|
| Artikelnummer identification code | 26001 | Fotos und Bilder dienen nur der Veranschaulichung. Abweichungen in Farbe und Form sind möglich! Photos and figures are for illustration onla. Colour and design ist not guaranteed. |
| Präzisionsstahlrohr - geschweisst, kaltgezogen | welded cold drawn precision steel tube | |
| 28,00x1,50 EN10305-2 +C E355-Option10 | 28,00x1,5-EN10305-2 +C E355-Option 10 | |

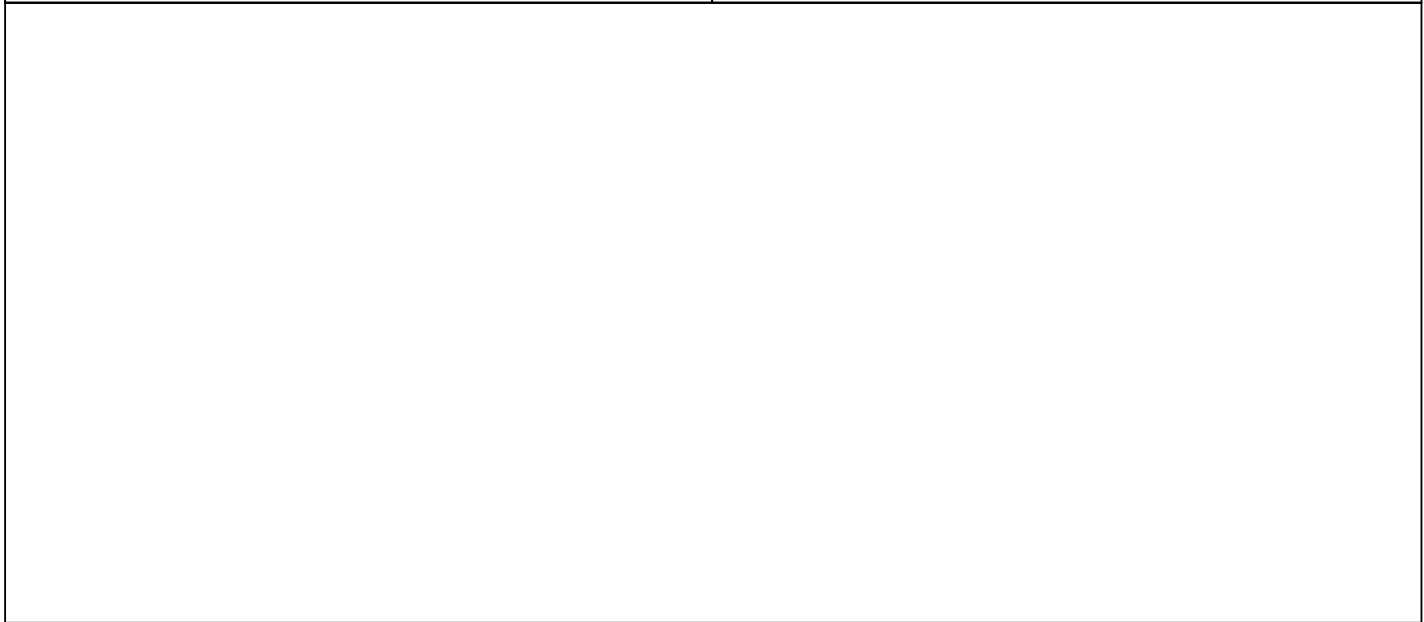

Gewicht: 0,980 kg

| | |
|----|-------|
| D1 | 28,00 |
| D9 | 1,50 |