

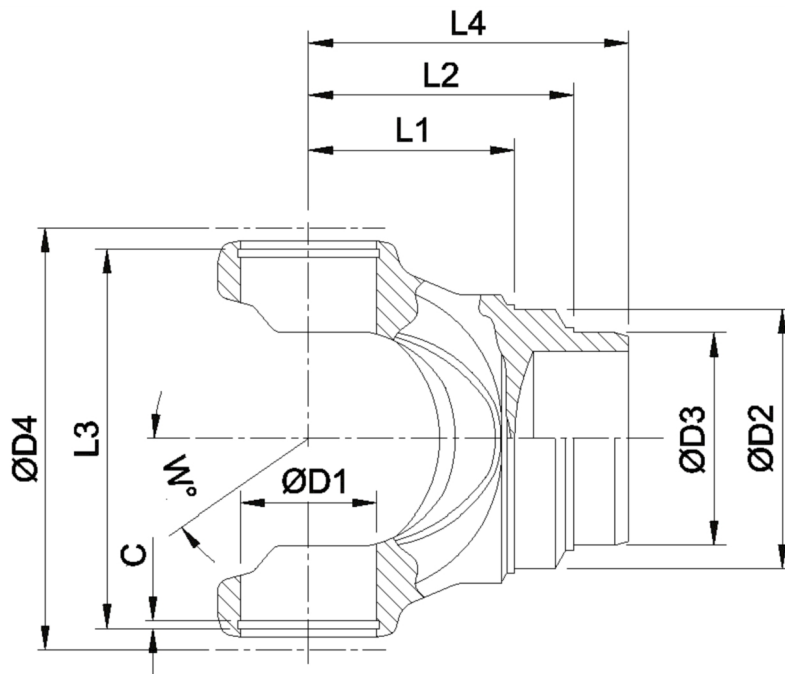

Artikelnummer identification code	<h1>0450196</h1>	Fotos und Bilder dienen nur der Veranschaulichung. Abweichungen in Farbe und Form sind möglich! Photos and figures are for illustration onla. Colour and design ist not guaranteed.
Schweisszapfen RA=54,3/64,3 / L2=72 / L1=58		tube yoke tc 54,3/64,3 / L2=72 / L1=58
für KR 30x81,8		for UJ 30x81,8



Gewicht: 1,300 kg

D1	30,00	L1	58,00	C	2,00	W	30°
D2	64,20	L2	72,00				
D3	54,20	L3	84,10				
		L4	85,00				