

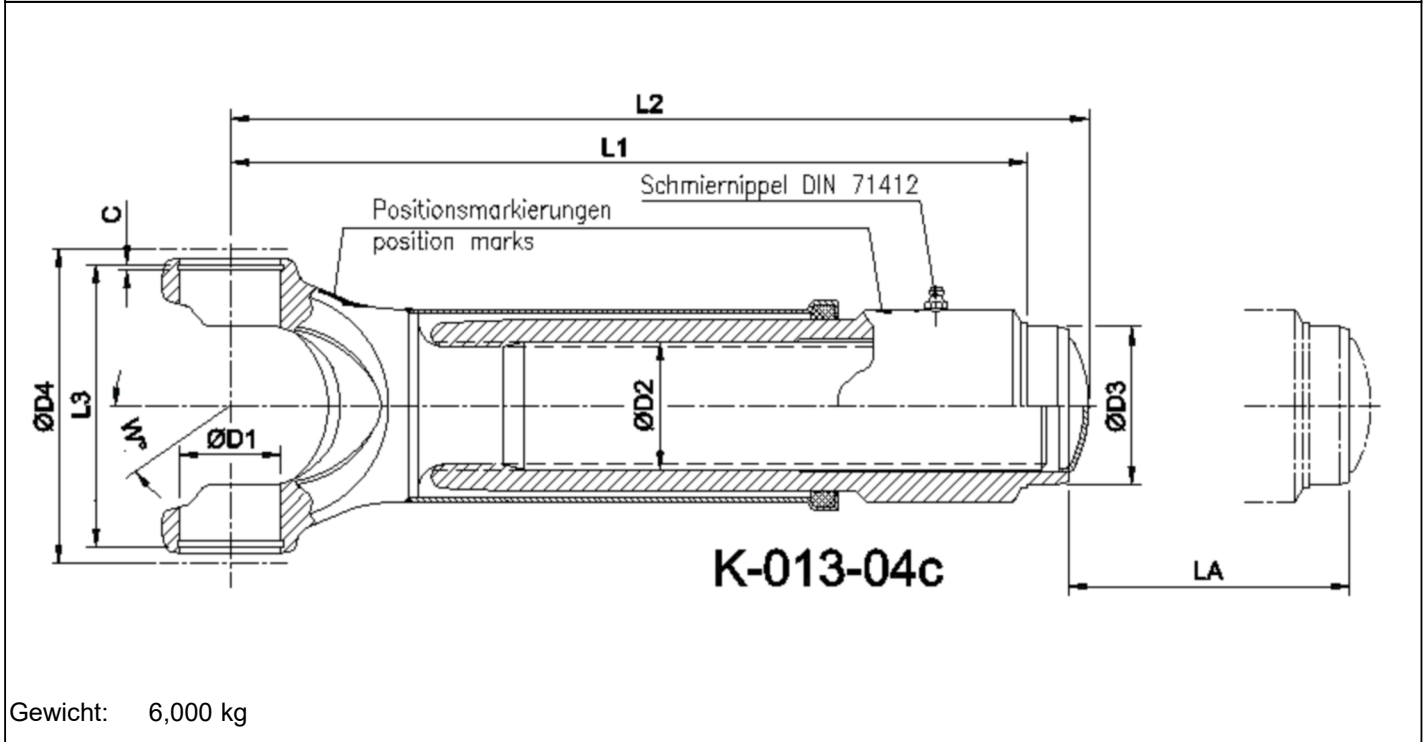

Artikelnummer identification code	<h1>0130070-1</h1>	Fotos und Bilder dienen nur der Veranschaulichung. Abweichungen in Farbe und Form sind möglich! Photos and figures are for illustration onla. Colour and design ist not guaranteed.
Gabelwellenverschiebung RA=84,3 / L1=295		slip assembly tc=84,3 / L1=295
für KR 42x106 / La=110		for UJ 42x106 / La=110



Gewicht: 6,000 kg

D1	42,00	L1	295,00	LA	110,00
D2	55,00	L2	306,00	W	25°
D3	84,30	L3	109,40		
D4	126,00				