

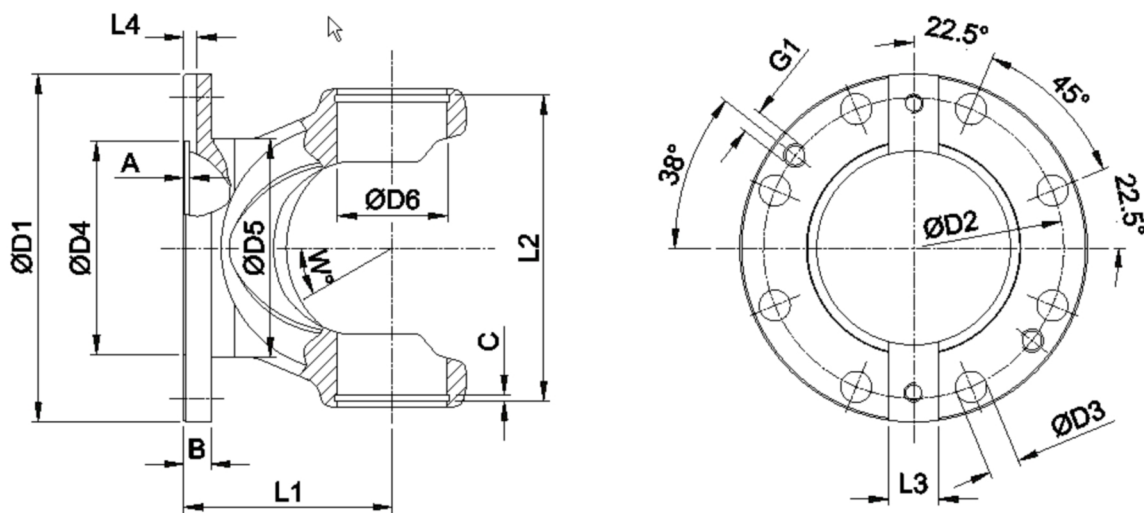

Artikelnummer identification code	<h1>0030664-1</h1>	Fotos und Bilder dienen nur der Veranschaulichung. Abweichungen in Farbe und Form sind möglich! Photos and figures are for illustration onla. Colour and design ist not guaranteed.
Gabelflansch DIN 225/8-17+2 Querkeile mit 2xM16 für KR 72x185 / L1=108	flange yoke FK 225/8-17 / L1=108 for UJ 72x185 / type 31c	



K-003-31c

Gewicht: 18,000 kg

D1	225,00	L1	108,00	A	5,00	W	24°
D2	196,00	L2	9,00	B	15,00		
D3	17,00	L3	32,00	G1	M16		
D4	140,00	L4	6,00				
D6	72,00						
D8	176,00						