

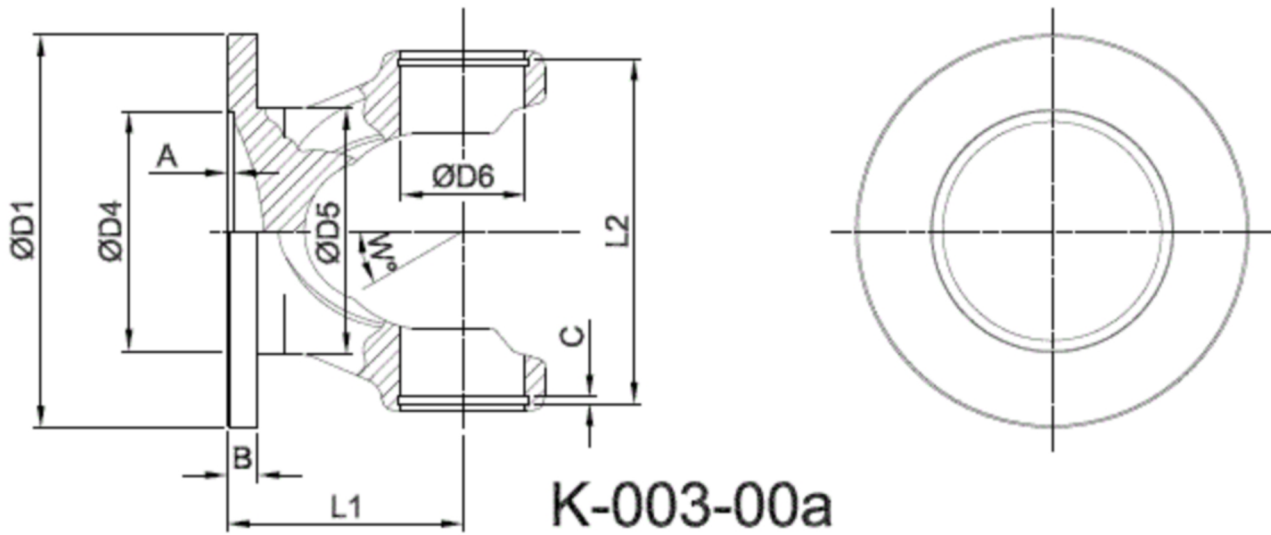

Artikelnummer identification code	0030354	Fotos und Bilder dienen nur der Veranschaulichung. Abweichungen in Farbe und Form sind möglich! Photos and figures are for illustration onla. Colour and design ist not guaranteed.
Gabelflansch DIN 180 unbebohrt / L1=95 für KR 57x152	flange yoke DIN 180 without holes / L1=95 for UJ 57x152	



Gewicht: 7,500 kg

D1	180,00	L1	95,00
D2	110,00		
D6	57,00		