

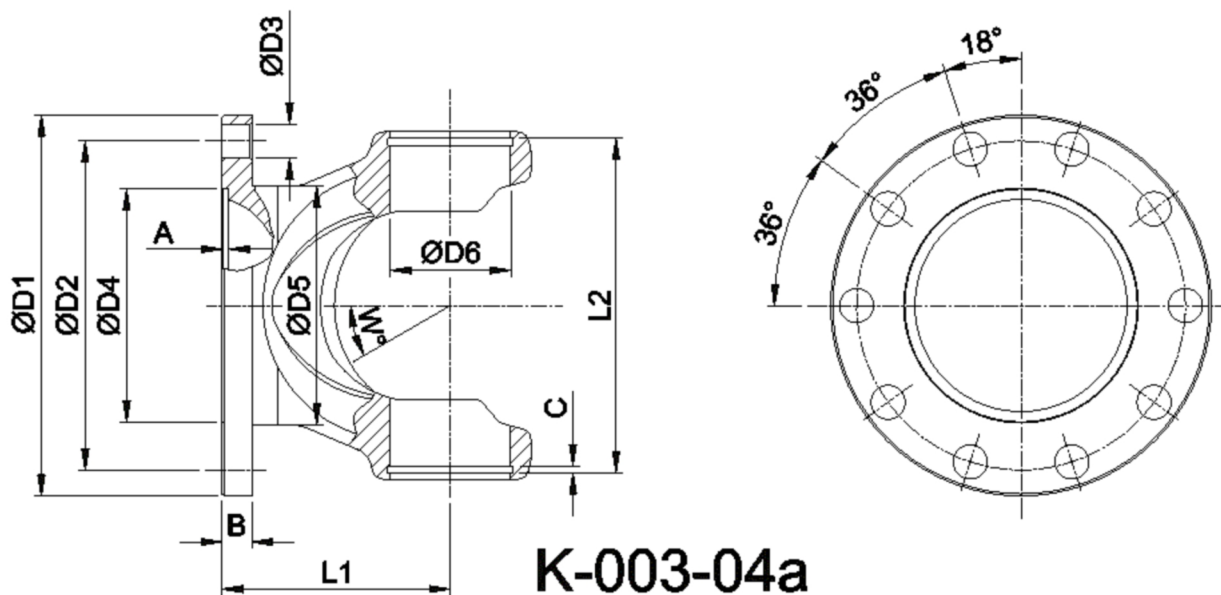

|  |   |  |
|--|---|--|
| Artikelnummer<br>identification code                 | <h1>0030120-4</h1>                                  | Fotos und Bilder dienen nur der Veranschaulichung.<br>Abweichungen in Farbe und Form sind möglich!<br><br>Photos and figures are for illustration onla. Colour<br>and design ist not guaranteed. |
| Gabelflansch DIN 180/10-16 / L1=100<br>für KR 57x144 | flange yoke DIN 180/10-16 / L1=100<br>for UJ 57x144 |  |



Gewicht: 6,900 kg

|    |        |    |        |   |       |   |     |
|----|--------|----|--------|---|-------|---|-----|
| D1 | 180,00 | L1 | 100,00 | A | 3,00  | W | 25° |
| D2 | 155,50 | L2 | 147,94 | B | 12,00 |   |     |
| D3 | 16,00  |    |        |   |       |   |     |
| D4 | 110,00 |    |        |   |       |   |     |
| D6 | 57,00  |    |        |   |       |   |     |