

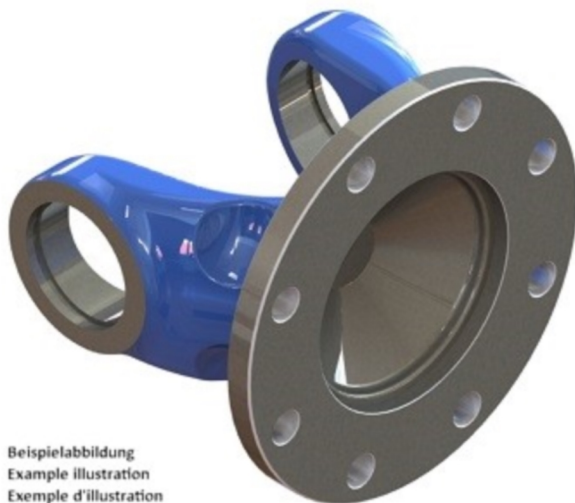

Artikelnummer identification code	<h1>0030583</h1>	Fotos und Bilder dienen nur der Veranschaulichung. Abweichungen in Farbe und Form sind möglich! Photos and figures are for illustration onla. Colour and design ist not guaranteed.
Gabelflansch DIN 315/8-22+2xM22 / L1=160	flange yoke DIN 315/8-22+2xM22 / L1=160	
für KR 115x243 Typ 03c	for UJ 115x243 typ 03c	

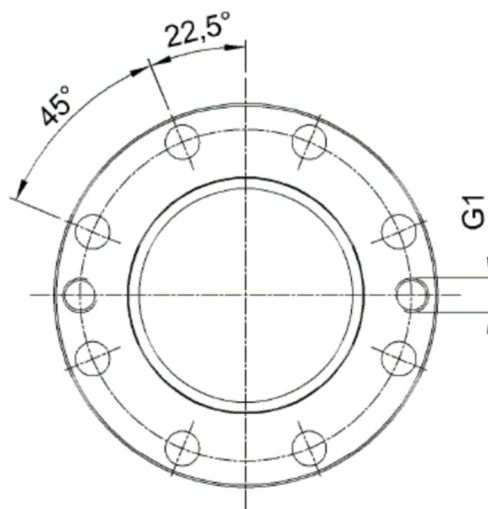

Beispielabbildung
Example illustration
Exemple d'illustration
Ilustración de ejemplo
Пример иллюстрации

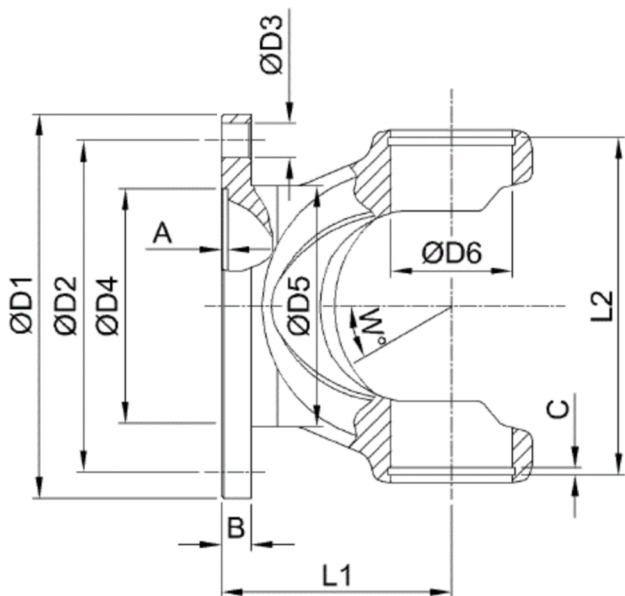

K-003-03c

Gewicht: 41,000 kg

D1	315,00	L1	160,00	A	7,00	W	15°
D2	280,00			B	22,00		
D3	22,00			G1	M22		
D4	175,00						
D6	115,00						