

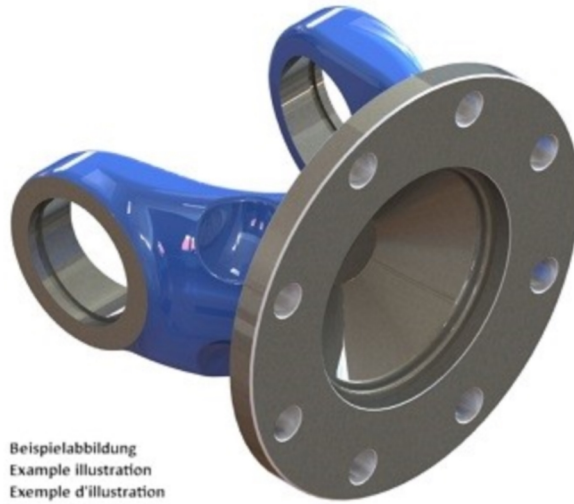

Artikelnummer identification code	<h1>0030502</h1>	Fotos und Bilder dienen nur der Veranschaulichung. Abweichungen in Farbe und Form sind möglich! Photos and figures are for illustration onla. Colour and design ist not guaranteed.
Gabelflansch DIN 120/8-10 / L1=56	flange yoke DIN 120/8-10 / L1=56	
für KR 35x97 - Typ 03a - Kalotte innen bearbeitet!	for UJ 35x96,8 - type 03a - machined cage	

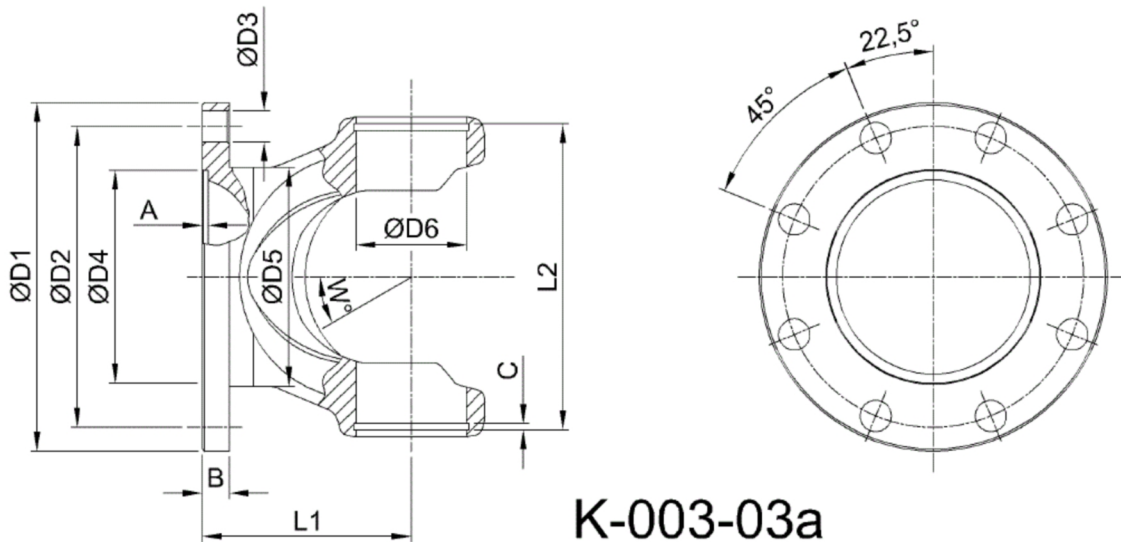

Beispielabbildung
Example illustration
Exemple d'illustration
Ilustración de ejemplo
Пример иллюстрации



K-003-03a

Gewicht: 0,000 kg

D1	120,00	L1	58,00	A	3,00	W	20°
D2	101,50			B	8,00		
D3	10,00						
D4	75,00						
D6	35,00						